

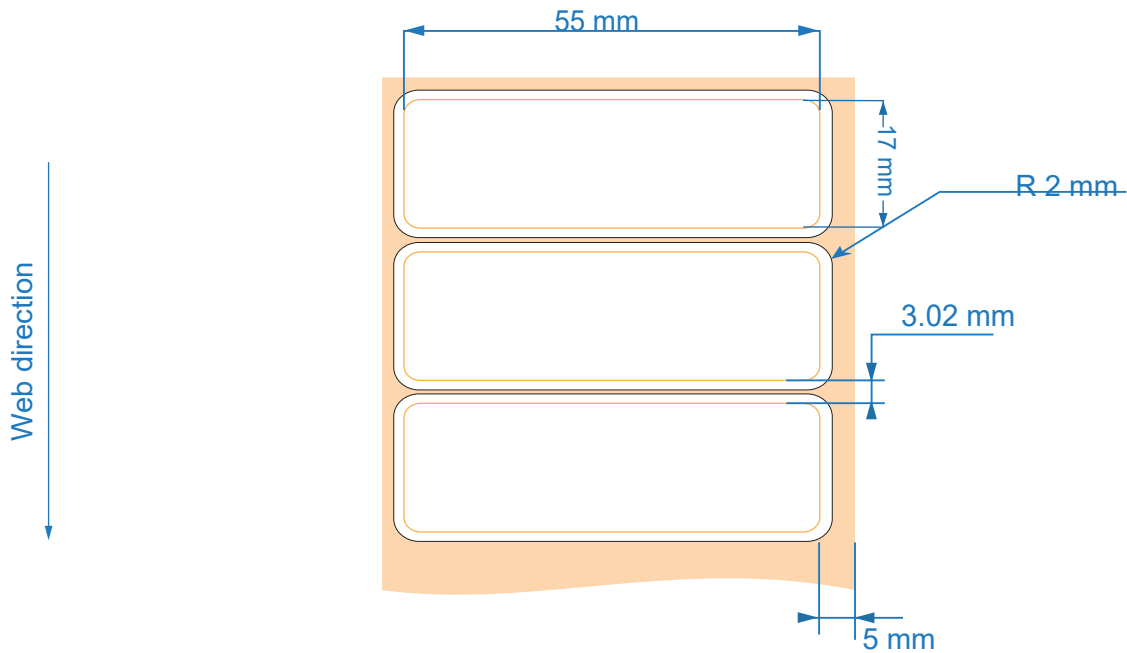

IDANIM
CREATIVE SOLUTIONS

ILBDWPP55X17-1

55x17 mm



CUSTOMER APPROVAL:	IDANIM PN :ILBDWPP55X17-1	CUST PN : 9220122	Importance of the scrolling direction <input checked="" type="checkbox"/> IMPORTANT <input type="checkbox"/> NOT IMPORTANT	Packaging 6 7 5 8
NAME:	MATERIAL : DURABLE POL	DRAWING NR. :		
SIGNATURE:	WINDING : OUT	INNER CORE : 1		
STAMP:	Knife number: 5434	TOLERANCE : ± 0,5 mm		
	COLORS : <input type="checkbox"/> WHITE <input checked="" type="checkbox"/> CUTTING LINE	SCALE:		
	OBSERVATION :	Format: DATE :1.8.24 REVISION: 01		
Idanim creative solutions: Moshe Hess St 7, Lod, Israel, Tel: 08-6225629 Fax: 08-6225629 e- mail: sales@idanimltd.com				

לקוח יקר - הצבעים הינם להמחשה בלבד לכן ייתכנו סטיות בגוון הצבע בין תצוגת מסך לצבע המודפס

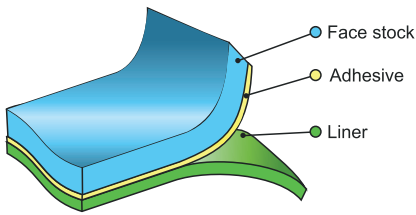

General Description:

A thermal transfer printable polyester film with print receptive top-coat, high performance extra permanent acrylic adhesive and glassine liner. This product can be delivered in white, silver and colored polyester.

Face stock



A gloss white polyester film. The smooth surface is covered with a topcoat for excellent ink anchorage.

Thickness:

SI Units	Test Method
250 micron	ASTM D 3652

Adhesive



The adhesive is a permanent acrylic adhesive with good initial tack and high ultimate adhesion onto a variety of substrates including apolar plastics and lacquers

Thickness:
Adhesion from:
Stainless Steel
Glass
Polypropylene
Automotive Paint
PBT
Shear
Probe Track

SI Units	Test Method
27 micron	ASTM D 3652
21 N/ 25mm	FTM 1 (72 hour dwell)
22 N/ 25mm	FTM 1 (72 hour dwell)
18 N/ 25mm	FTM 1 (72 hour dwell)
19 N/ 25mm	FTM 1 (72 hour dwell)
18 N/ 25mm	FTM 1 (72 hour dwell)
50 Hours	FTM 8 (1h dwell /2kg wheat)
720 (459) gram/sq cm	ASTM d 2979

Liner



The liner is a supercalendered glassine paper.

Caliper:

SI Units	Test Method
56 micron	ASTM D 3652
10°C	
-40 °C to +150 °C	

Shelf life



Material is stable for two years stored at max 21 °C and 50% relative humidity. Damp conditions, excessive heat and/or freezing conditions should be avoided.